

CT1500 AND CT2500

CHARGEPOINT NETWORKED CHARGING STATIONS

The CT1500 and CT2500 families of ChargePoint™ Networked Charging Stations, manufactured by Coulomb Technologies, are specifically designed for the European market. The CT1500 family of charging stations supports 230V @ 16A (CEE7 or BS 1363 socket) charging. The CT2500 family of charging stations supports both 230V @16A (CEE7 or BS 1363 socket) and 230V @ 32A (SAE J1772™ Document) charging.

The ChargePoint Networked Charging Stations combined with the ChargePoint Network Operating System (NOS) form a smart charging infrastructure for plug-in electric vehicles called the ChargePointSM Network. Each local group of charging stations automatically forms a robust self-healing Radio Frequency (RF) mesh network managed by a single gateway charging station—a version of the networked charging stations incorporating an embedded GSM cellular modem in addition to RF mesh network functionality. Up to 100 charging stations can communicate to and be managed by a single gateway charging station. The gateway charging station, in turn, utilizes the local cellular network to communicate with the ChargePoint NOS, which runs on a remote secure hosted server managed by Coulomb Technologies. The ChargePoint NOS provides multiple web-based portals for drivers, charging station owners, installers, fleet operators, and utility companies.

Coulomb's ChargePoint NOS communicates with and individually controls the networked charging stations in order to provide authentication, management, and real-time control. The ability to individually control each charging station in real time allows the ChargePoint Network to be open to all drivers of plug-in vehicles. Drivers have the option of paying for a single charging session by placing a toll free call to the 24/7 number on each charging station or they can become a ChargePoint Network subscriber by going to www.mychargepoint.net and choosing a monthly subscription plan that fits their lifestyle. Other future payment options include using any smart (RFID) credit/debit card to authorize a session or using a standard credit or debit card at a remote payment station (RPS) to pay for charging sessions. The ChargePoint Network has been designed with an open, standards-based architecture. Drivers who are members of other charging systems will be able to use their authorization smart cards at any ChargePoint networked charging station just like they can roam between cell phone networks.

ChargePoint Networked Charging Stations perform bi-directional energy metering via an embedded utility grade electronic meter. The ability to precisely measure and report electricity use enables a sustainable, flexible business model that meets the needs of drivers, corporations, fleet operators, utility companies and municipalities. This revenue generating business model includes flexible subscriber payment methods like “free” charging, pay per use, by subscription, and by kWh (where allowed).

NETWORKING CAPABILITIES AND BENEFITS

ChargePoint Networked Charging Stations provide unique benefits when compared to non-networked charging stations. Those benefits include:

- A charging infrastructure open to all drivers without requiring subscriptions
- A revenue stream to pay for electricity, capital equipment and maintenance
- Ability for drivers to find unoccupied charging stations via web-enabled cell phones
- Notification by SMS text or email when charging is complete
- Authenticated access to eliminate energy theft
- Authorized energizing for safety
- Remote monitoring and diagnostics for superior quality of service
- Smart Grid integration for utility load management with future V2G capabilities
- Green House Gas savings calculation per driver and per fleet
- Fleet vehicle management



Coulomb Technologies, Inc.
1692 Dell Ave.
Campbell, CA 95008-6901 USA
US toll free: +1-877-370-3802
info@coulombtech.com
www.coulombtech.com
www.mychargepoint.net



MECHANICAL DRAWINGS CT1500 FAMILY

BOLLARD (CT1501)

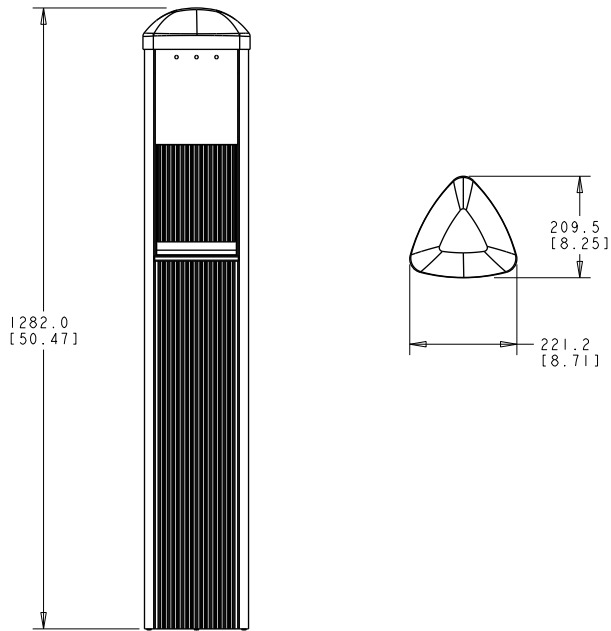

POLE MOUNT (CT 1502)

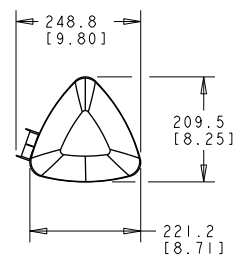

WALL MOUNT (CT1503)

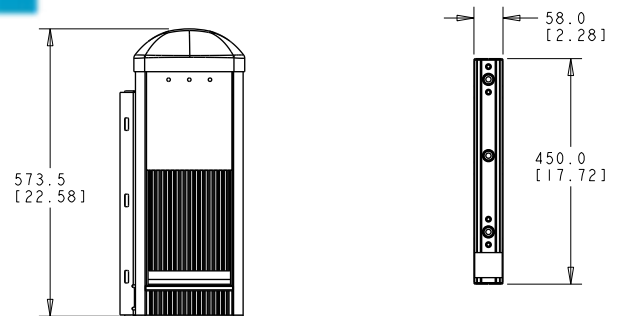
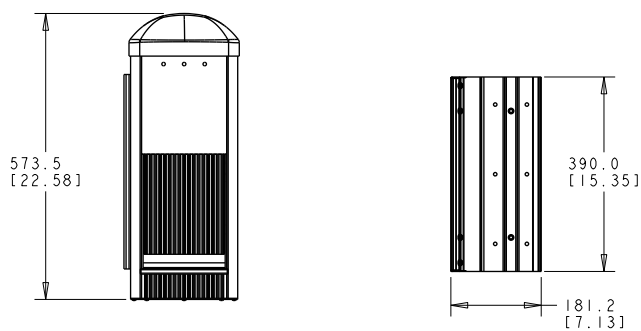
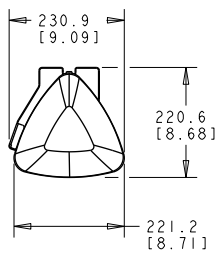

Coulomb Technologies reserves the right to alter product offerings and specifications at any time without notice, and is not responsible for typographical or graphical errors that may appear in this document.



CHARGEPOINT NETWORKED CHARGING STATION INSTALLATION OPTIONS

Both the CT1500 and CT2500 ChargePoint Networked Charging Stations are available in three mounting configurations:

BOLLARD



POLE MOUNT



WALL MOUNT



| PRELIMINARY SPECIFICATIONS | CT1500 FAMILY (230V @ 16A) | CT2500 FAMILY (230V @ 16A & 230V @ 32A) |
|--|---|--|
| Charging Connection | CEE7 or BS1363 outlet | 230V @ 16A; CEE7 or BS1363 outlet 230V @ 32A; SAE J1772™ Document (plug on 5m cable) |
| AC Charging Power Output | 3.7kW (230V at 16A) | 230V @ 16A; 3.7kW and 230V @ 32A; 7.4kW Note only one output enabled at any time. |
| AC Power Input; Connections | 230V 20A 1 Phase; Line, Neutral, and Earth | 230V 40A 1 Phase; Line, Neutral, and Earth |
| Recommended Service Panel Breaker | 20A breaker on dedicated circuit | 40A breaker on dedicated circuit |
| Recommended Service Panel RCD | None. Do not provide RCD at service panel as it can conflict with integral RCD | |
| Integral Hardware RCD | 20mA with ground continuity monitor and auto retry (15 min delay, 3 tries) | |
| Automatic Plug-Out Detection | Programmable arm and trip current thresholds (patent pending) | |
| Power Measurement | 1% @ 5 min interval; IEC class 1 capable (special order) | |
| Local Area Network | 2.4GHz 802.15.4 dynamic mesh network | |
| Wide Area Network | Commercial GPRS cellular data network | |
| Network Communication Protocol | TCP/IP | |
| Network Security | HTTPS; 128-bit AES Encryption | |
| Maximum Charging Stations per 802.15.4 Radio Group | 100 Each charging station within 50m of at least one other station | |
| Smart Card Reader | ISO 15693 compliant | |
| Standby Power | 2W typ. | |
| Outdoor Rated | IP44 per IEC 60529 | |
| Safety Compliance | IEC 61851-1, -21, -22 | |
| Surge Protection | 6kV @ 3,000A per IEC1000-4-5 In geographic areas subject to frequent thunder storms supplemental surge protection at service panel is recommended | |
| EMC | EN 61000-6-3 Class A, EN 61000-6-2 | |
| Operating Temperature | -30°C to +60°C | |
| Operating Humidity | Up to 95% | |
| Voltage and Current Rating | 230VAC @ 20A | |
| Terminal Block Temperature Rating | 100°C | |
| Approximate Shipping Weights | Bollard (CT1501) 23kg Pole Mount (CT1502) 14kg Wall Mount (CT1503) 15kg | Bollard (CT2501) 28kg Pole Mount (CT2502) 19kg Wall Mount (CT2503) 20kg |

CT1500 AND CT2500

CHARGEPOINT NETWORKED CHARGING STATIONS

FEATURES



- Smart Card: open, standards-based RFID provides authorized network access control preventing electricity theft, enhancing safety, and minimizing liability
- Automatic SMS Text and/or Email Notification: alerts drivers of events and issues
- High Availability: real-time remote control monitoring and management features, minimizes station downtime and enables start/stop charging sessions with lock/unlock door
- 24/7 ChargePoint Network Customer Support
- Advanced Safety Features (CEE7 and BS1363): power not energized until:
 1. User is authorized
 2. Plug is fully inserted
 3. Door is relocked
- Locking Door: (CEE7 and BS1363): retains the charging cord to prevent theft, with auto unlock in case of power outage
- Auto Plug-out Detect: (CEE7 and BS1363) automatically detects if charging cord has been un-plugged at the vehicle, de-energizes outlet and optionally notifies driver (patent pending)
- RCD: integral hardware ground-fault protection circuitry with auto retry minimizes nuisance RCD trips
- Fast Over-Current Detect at Charging Station: minimizes nuisance breaker trips at service panel
- Bi-Directional, Utility-Grade Power Measurement: integral power metering circuitry provides accurate measurement of energy delivered for charging and allows calculation of Green House Gas savings
- Wide Area Network Connection - GSM: only one gateway charging station with cellular modem required per local group of charging stations
- HTTPS and 128-bit AES Encryption: ensures secure network communications
- Integrated RFID Reader: recognizes and identifies ChargePoint Network Smart Cards, RFID credit cards and authorization smart cards from other charging systems
- Future Proofed: all firmware can be upgraded remotely via the network as new capabilities and functionality become available
- Electric Utility Demand-Side Management: communication via HTTPS secure link to Utility and third party "Smart Grid" management systems provides real-time load shedding of any group of charging stations
- Vacuum Fluorescent Display: bright and easy to read
- CE mark: certified for conformity throughout the EU

Coulomb Technologies, Inc.
1692 Dell Ave.
Campbell, CA 95008-6901 USA
US toll free: +1-877-370-3802
info@coulombtech.com
www.coulombtech.com
www.mychargepoint.net